

► MASTHEAD F78 IMS80

2004

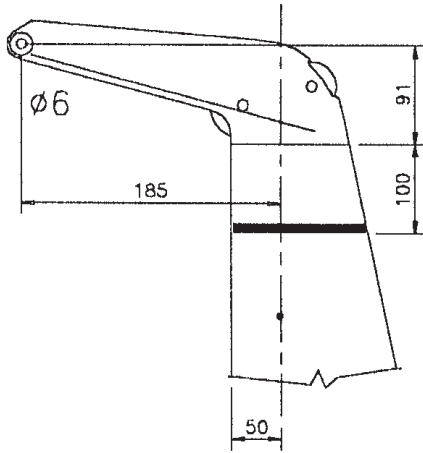
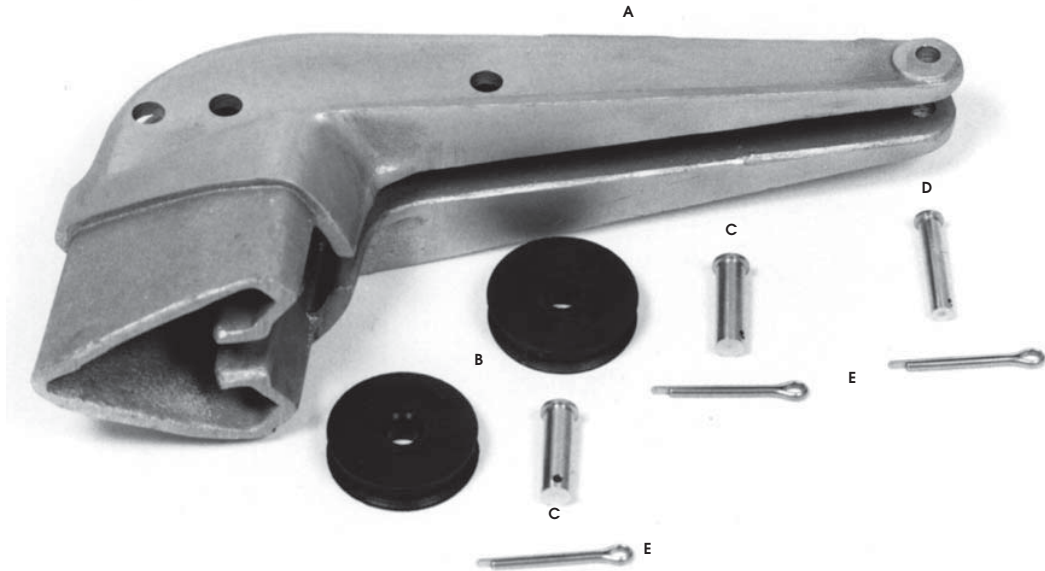

Front taper standard length 1 500 mm.

30008010785 * COMPLETE MASTHEAD WITH TOPPING LIFT.

Ref.	Description	Qt	
30008010783	ANOD.ALU BODY F78/IMS80	1	
48530401015	SHEAVE ACETAL 40X10 INJECT	1	
48510271015	SHEAVE delrin 27X10 INJECTE	2	
40020208024	STAINLESS STEEL PIN 8X24	3	
40020206028	STAINLESS STEEL PIN 6X28	1	
28803020160	STAINLESS STEEL SPLIT PIN D2X16	4	
29002248120	S/s RIVET 4,8X12	4	
29002248160	S/s RIVET 4,8X12	2	

30008010786 *COMPLETE MASTHEAD WITH SPI HALYARD WITHOUT TOPPING LIFT.

Ref.	Description	Qt	
30008010783	BODY F78/IMS80 ANOD. ALU	1	
48530401015	ACETAL INJECTE SHEAVE 40X10	2	
40020208024	STAINLESS STEEL PIN 8X24	2	
40020206028	STAINLESS STEEL PIN 6X28	1	
28803020160	STAINLESS STEEL SPLIT PIN D2X16	3	
29002248120	S/s RIVET 4,8X12	4	
29002248160	S/s RIVET 4,8X16	2	

* Assembly : **Stainless rivet 4 x 29002248120**
Stainless rivet 2 x 29002248160